

1. Mounting base plate OL 200

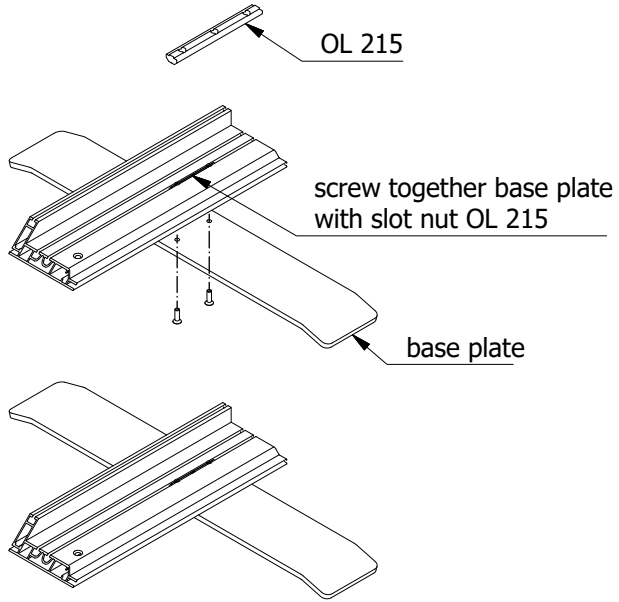

1a. Alternative: Mounting adjustable foot W 2850

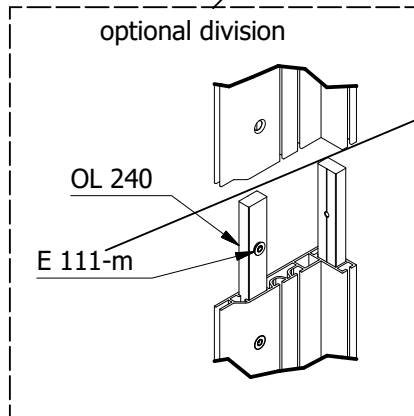
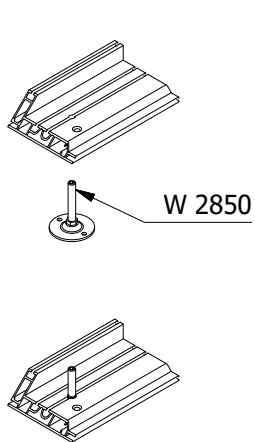

2. Mounting frame parts

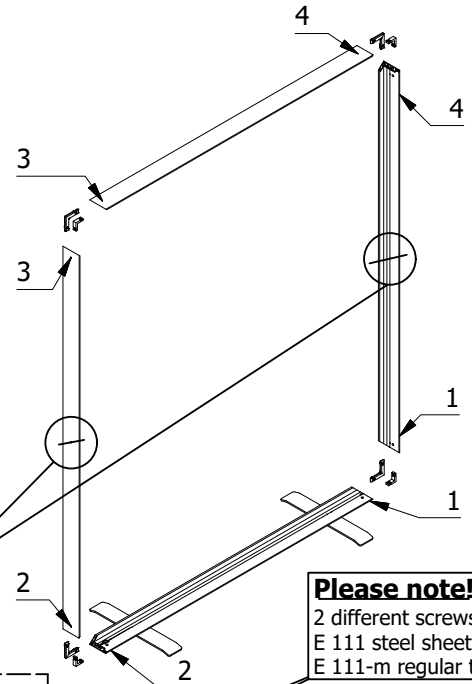

**Please note!**  
2 different screws are used.  
E 111 steel sheet thread (DIN 7970)  
E 111-m regular thread (DIN 7991)

3. Wiring in corners

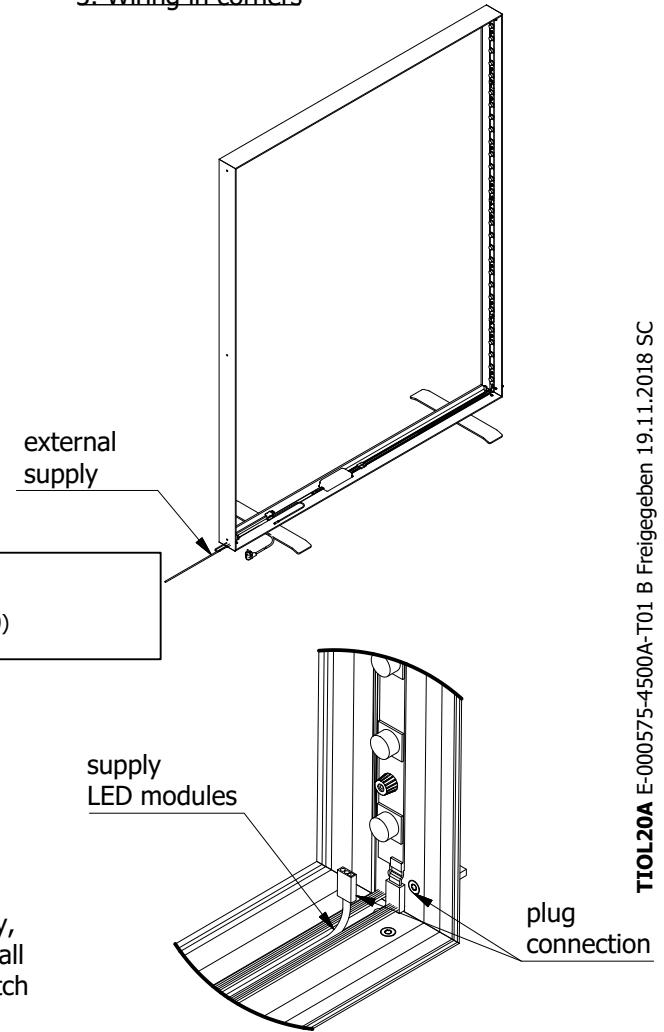

**Run function test of LEDs!**

TIOL20A E-000575-4500A-T01 B Freigegeben 19.11.2018 SC

4. Mounting bracing

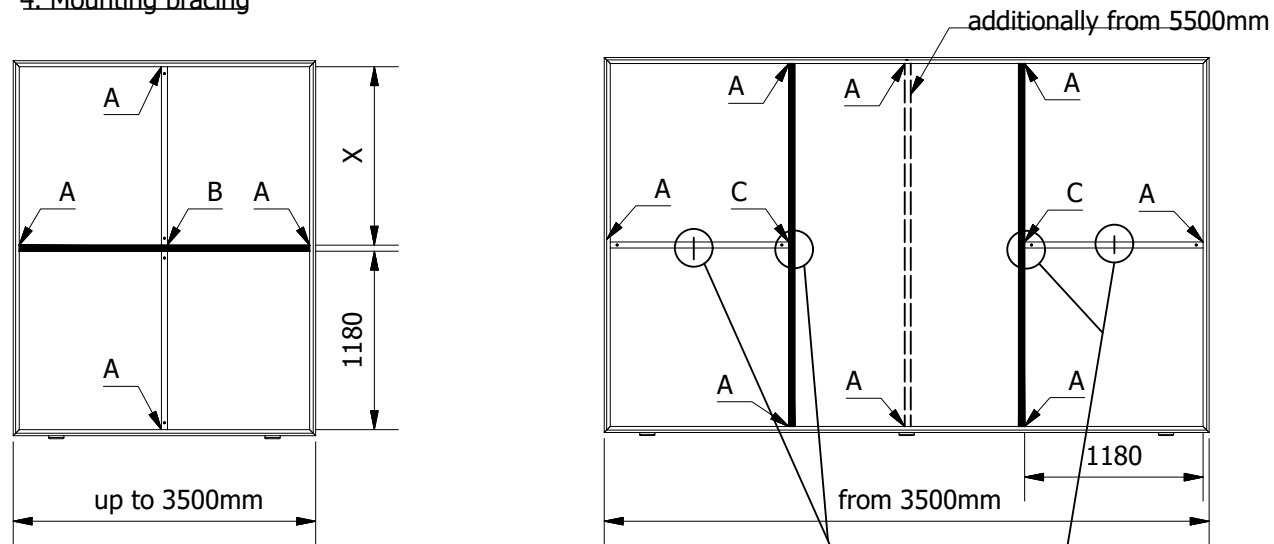

5. Mounting fabric infill

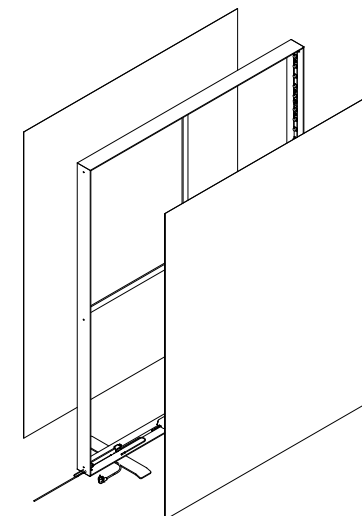

Position of frame bracing

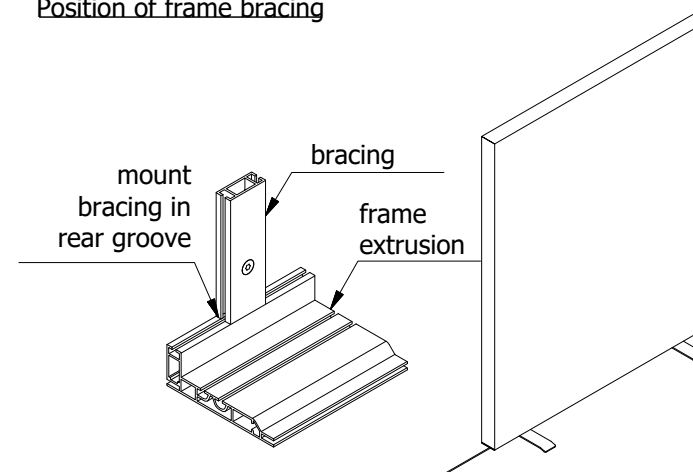
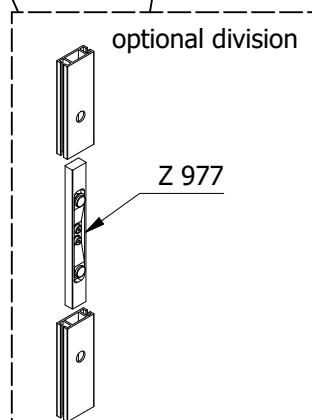
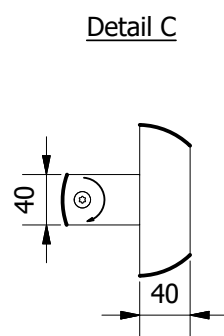
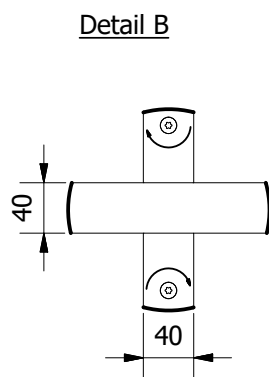
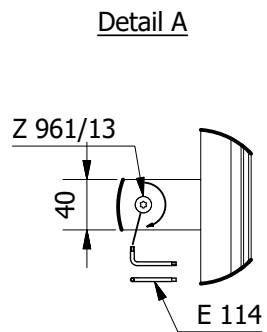

TI0120A E-000575-4500A-T02 B Freigegeben 19.11.2018 SC