

Beam with tie rod tensioning, 13.74 m long

TI-M-34.0

technical information

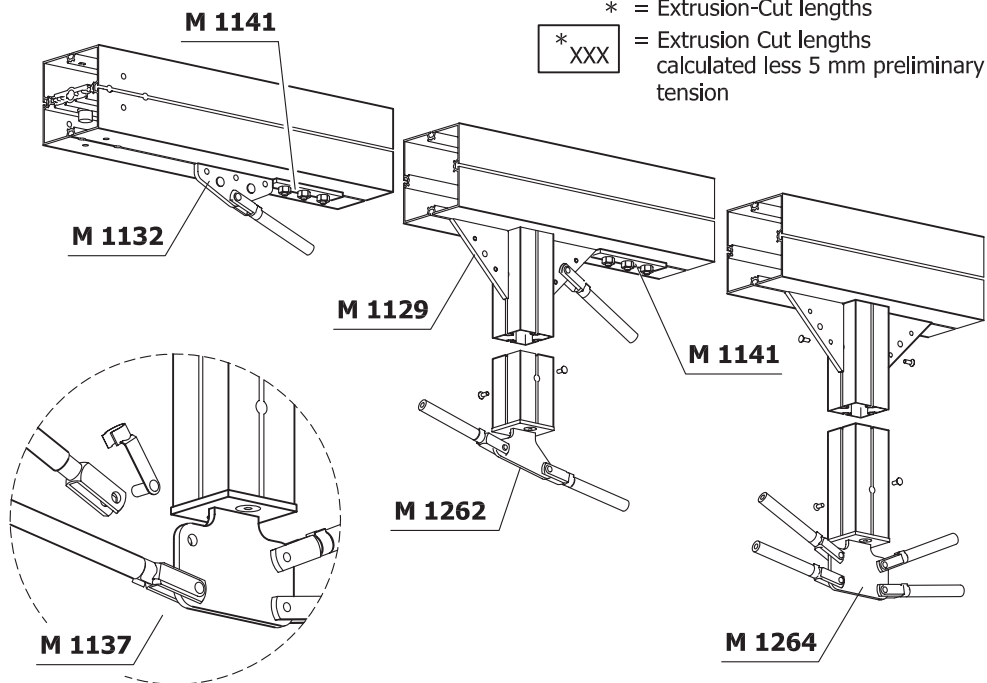
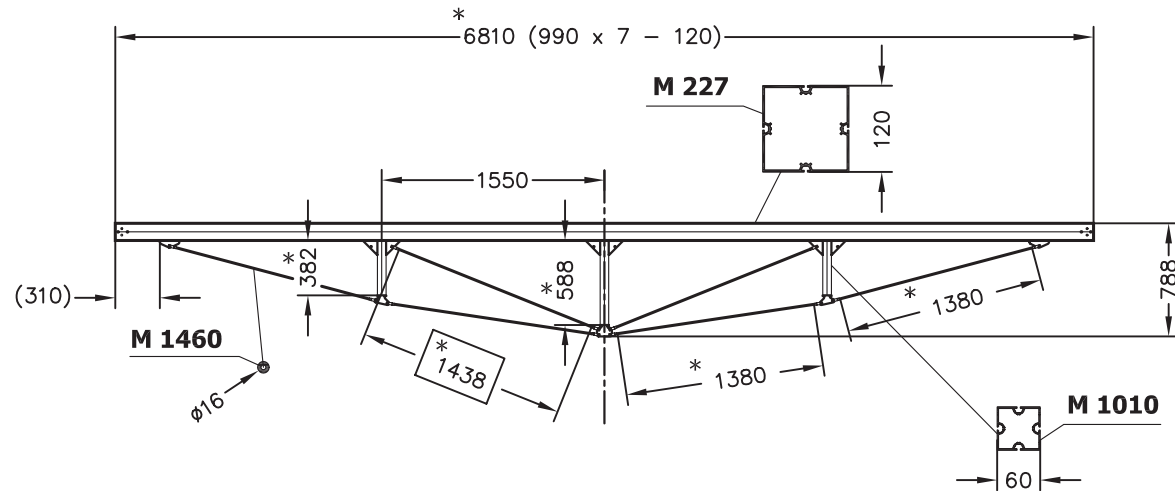

Part-List:			
Quantity	Art.-No.	Length:	Description:
1	M 227	6810	Square Extrusion, drilling on both sides (universal) for Adaptor M 1102
2	M 1010	382	Square Extrusion, drilled on both sides for Adaptor, rotated 90°
1	M 1010	588	Square Extrusion, drilled on both sides for Adaptor, rotated 90°
3	M 1100		Tension Lock Adaptor mounted
3	M 1555		Adaptor (without tension lock) mounted
4	M 1460	1380	Round Tube, on both side M 1137, mounted
2	M 1460	1438	Round Tube, on both side M 1137, mounted
6	M 1129		Angle reinforcement
1	M 1264		Tension brace junction node with 4 drillings
2	M 1262		Tension brace junction node with 2 drillings, bevelled
4	M 1141		Anti-slipping device
2	M 1132		Connector part

TIM-34.0 EW 2837.05 22.08.06, gez:VG geät:ED