

# Beam with tie rod tensioning, 11.76 m long

TI-M-34.1

## technical information

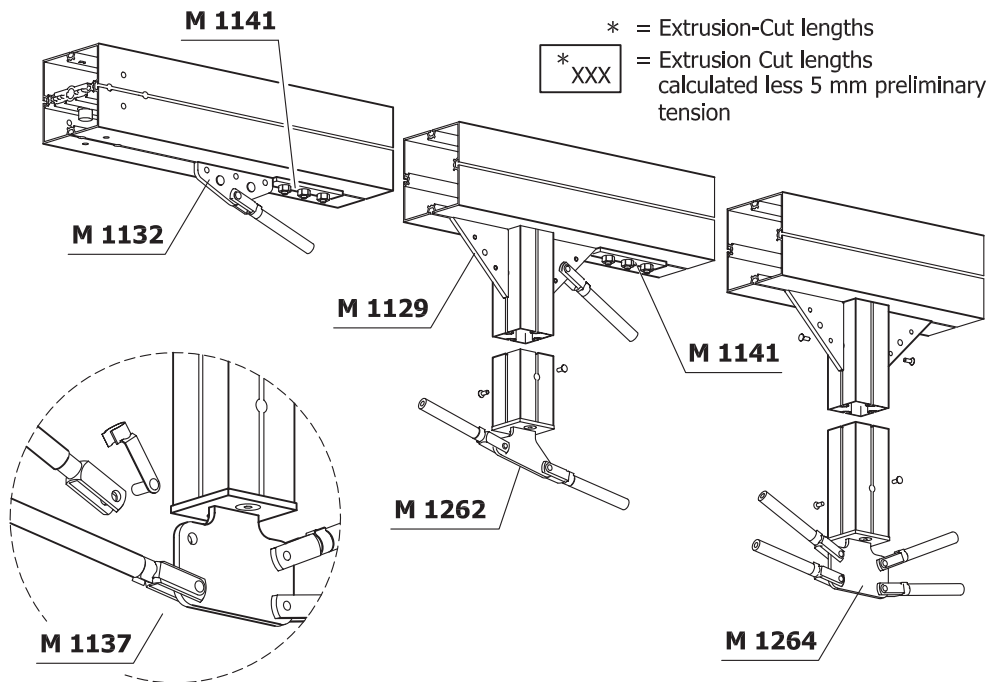
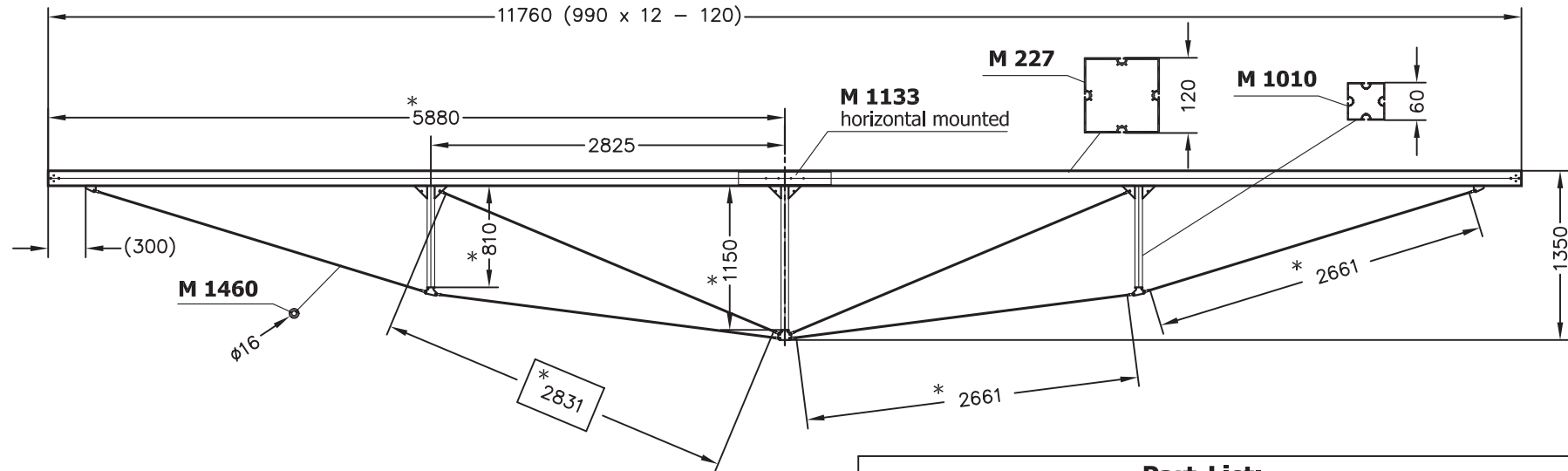

Part-List:			
Quantity	Art.-No:	Length:	Description:
2	M 226	5880	Square Extrusion, drilling on both sides (universal) for Adaptor M 1102
1	M 1133	720	Extension Adaptor
2	M 1010	810	Square Extrusion, drilled on both sides for Adaptor, rotated 90°
1	M 1010	1150	Square Extrusion, drilled on both sides for Adaptor, rotated 90
3	M 1100		Tension Lock Adaptor mounted
3	M 1555		Adaptor (without tension lock) mounted
4	M 1460	2661	Round Tube, on both side M 1137, mounted
2	M 1460	2831	Round Tube, on both side M 1137, mounted
6	M 1129		Angle reinforcement
1	M 1264		Tension brace junction node with 4 drillings
2	M 1262		Tension brace junction node with 2 drillings, bevelled
4	M 1141		Anti-slipping device
2	M 1132		Connector part

TIM-34.1 EW 2837.06 22.08.06, gez:VG geät:ED