

\* = Cutting length of the extrusion

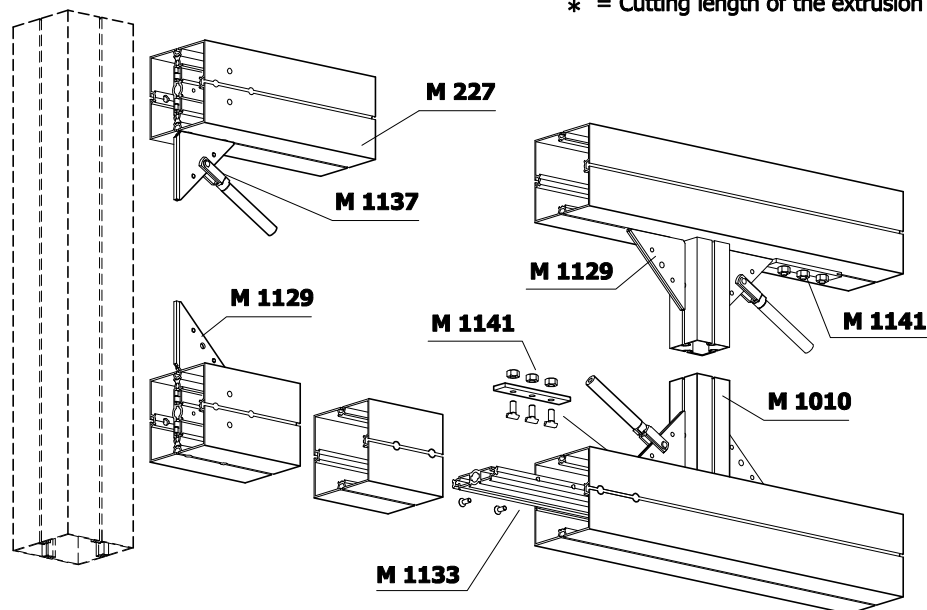

### Parts list for Truss girder M 744

Quantity	Art.-No:	Length:	Description:
2	M 227	6870	Square extrusion with each 4 drillings for M 1133 and drillings (with 90° turn) for adaptor M 1102 on one side
2	M 227	3395	Square extrusion with each 4 drillings for M 1133 and drillings (with 90° turn) for adaptor M 1102 on one side
1	M 227	6950	Square extrusion with 4 drillings for M 1133 on both sides
3	M 1010	1360	Square extrusion drilled for adaptor on both sides
4	M 1102		Tension lock adaptor mounted
6	M 1100		Tension lock adaptor mounted
4	M 1460	3435	Round tube with M 1137 mounted on both sides
3	M 1133	720	Extension adaptor
16	M 1129		Angle reinforcement
4	M 1141		Anti-slipping device

**Attention :** Truss systems differing from the standard ones must be recalculated by a structural engineer