

\* = Cutting length of the extrusion

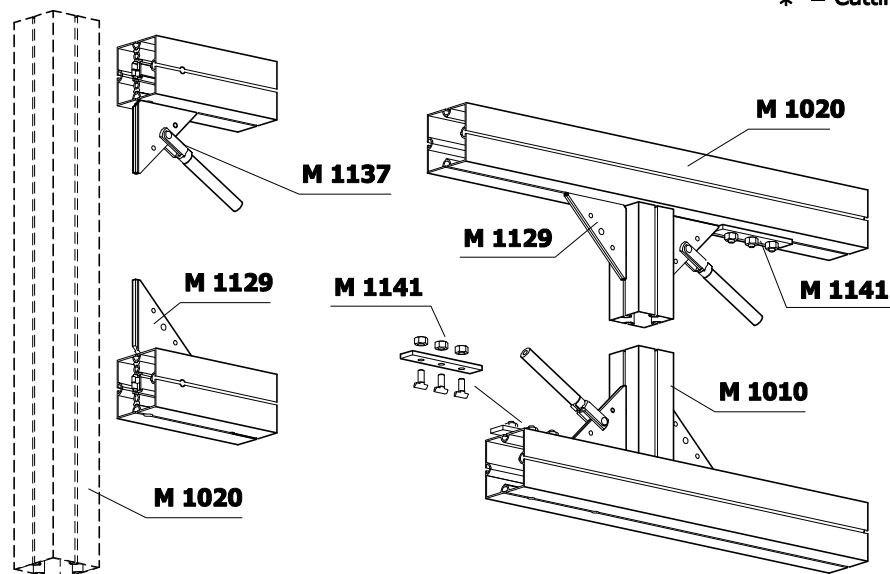

Parts list for Truss girder M 746			
Quantity	Art.-No:	Length:	Description:
2	M 1021	5860	Square extrusion with each 4 drillings for M 1101 on both sides
3	M 1010	560	Square extrusion drilled for adaptor on both sides
4	M 1101		Tension lock adaptor mounted
6	M 1100		Tension lock adaptor mounted
4	M 1460	1310	Round tube with M 1137 mounted on both sides
16	M 1129		Angle reinforcement
4	M 1141		Anti-slipping device

**Attention :** Truss systems differing from the standard ones must be recalculated by a structural engineer