

* = Cutting length of the extrusion

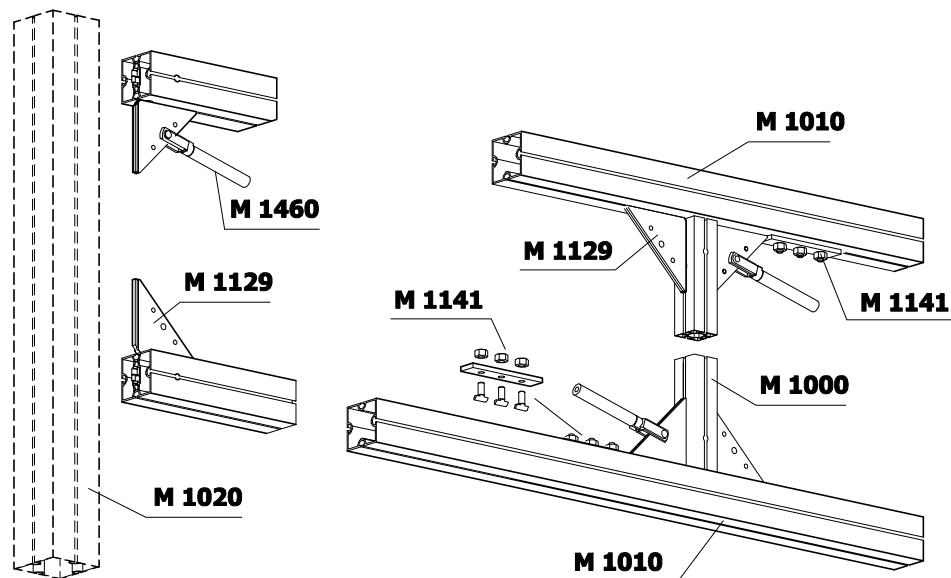

Parts list for Truss girder M 785

Quantity	Art.-No:	Length:	Description:
2	M 1010	4870	Square extrusion with drillings for adaptor M 1100 on both sides
3	M 1000	280	Square extrusion punched for Z 961/8 on both sides
4	M 1100		Tension lock adaptor mounted
6	Z 961/8		Tension lock mounted
4	M 1460	1013	Round tube with M 1137 mounted on both sides
16	M 1129		Angle reinforcement
4	M 1141		Anti-slipping device

Attention : Truss systems differing from the standard ones must be recalculated by a structural engineer