

Drilling  
dimensions :

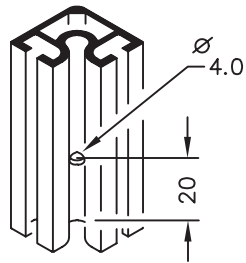

Knuckle joint V 2070

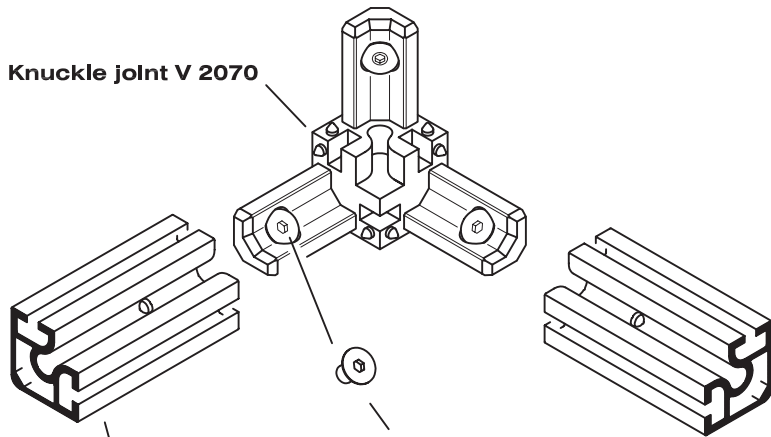

Countersunk screw  
M5 x 8, DIN 7991

Aluminium extrusion V 2000

Mounting instruction :

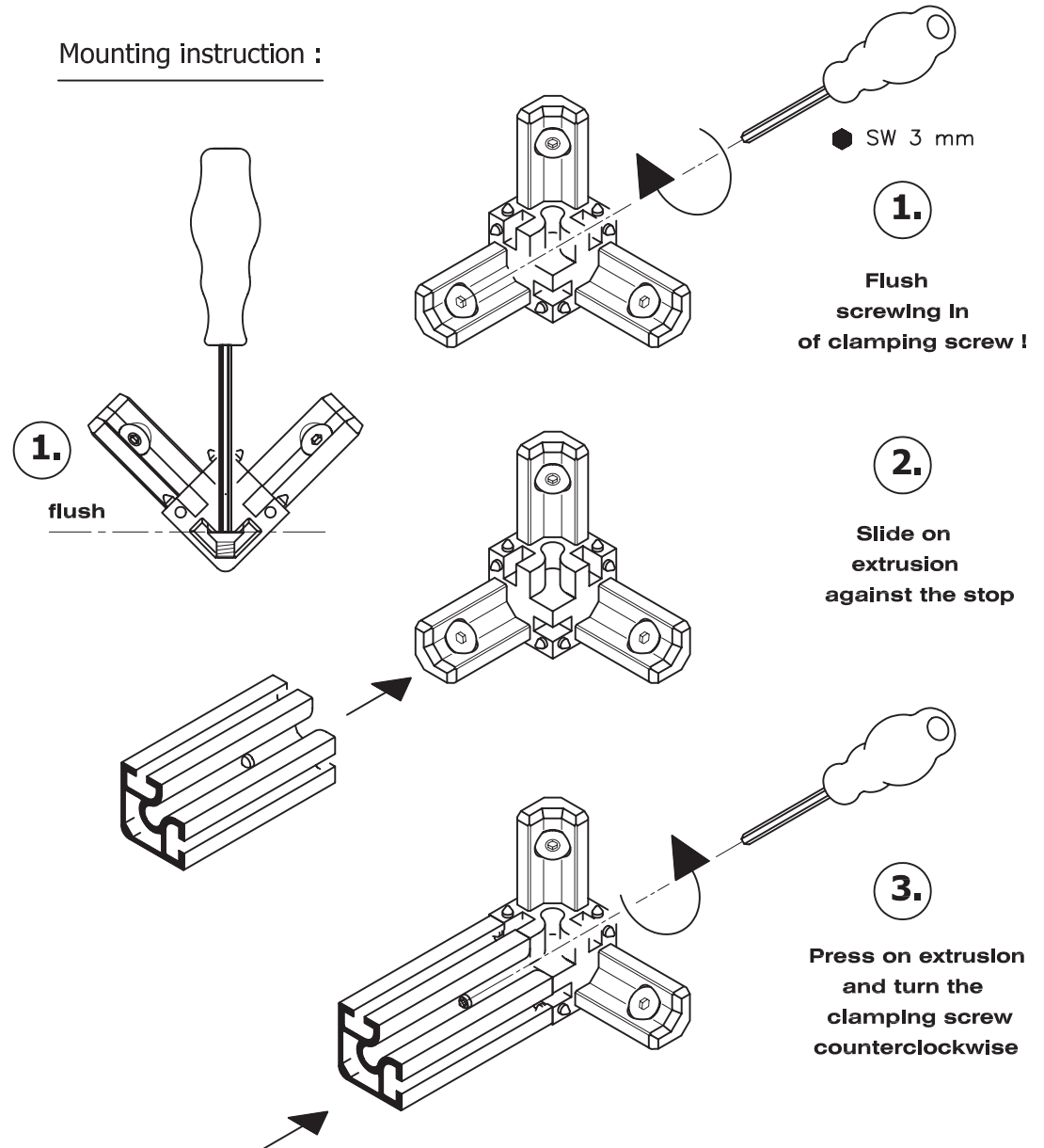

TI-NL-105 EV 2882-00 28.09.06, gez:HB, 29.03.07, geät: HB shift:07.07