

Instructions for use of beam extrusions: Punching for tension lock mounting

TI-NL-34

technical information

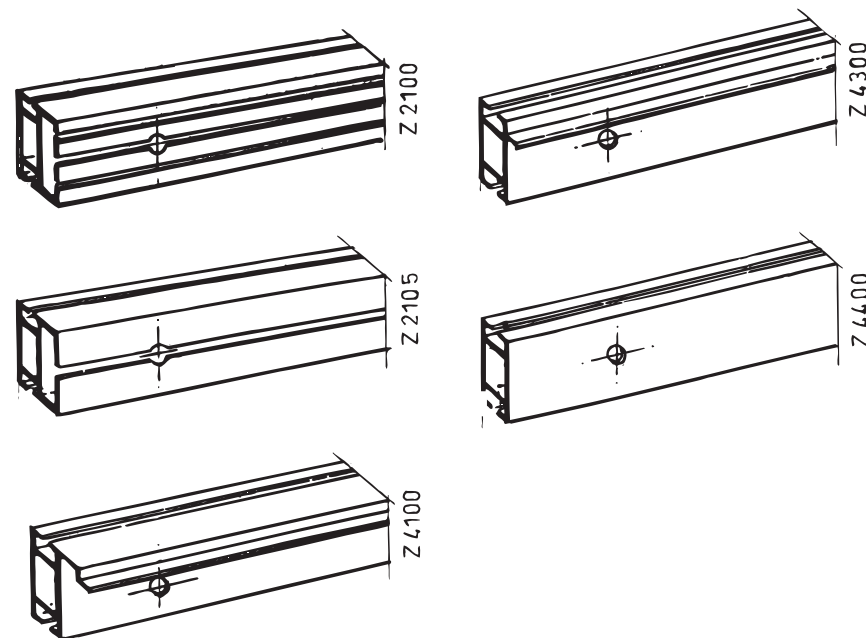
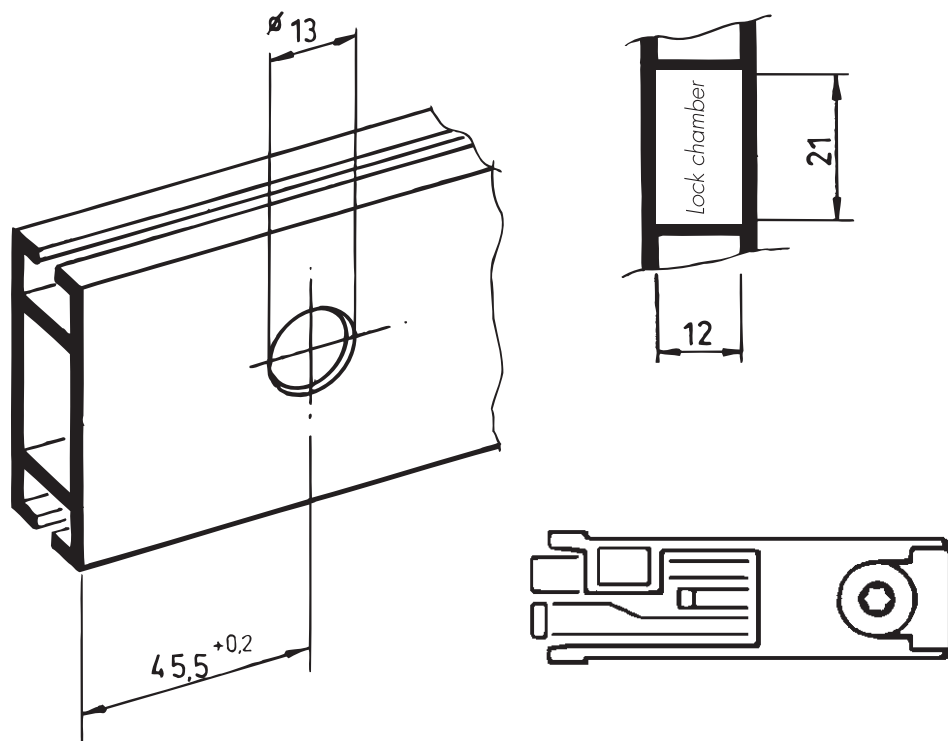

For punching at both ends minimum length 125 mm

Press eccentric head;
insert in beam till it locks

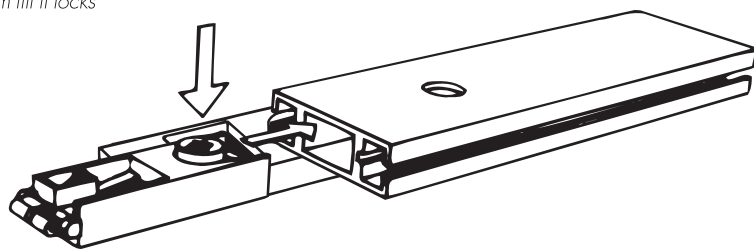

Important:
For exact punching use drilling jig BS 6 at choice with distance piece
(see catalogue "Tools for Mechanical Treatment")

TI NL-34 09/05 SHIFT