

Mounting of beam M 1602 / M 1603 to the upright extrusion

TI-NL-67

technical information

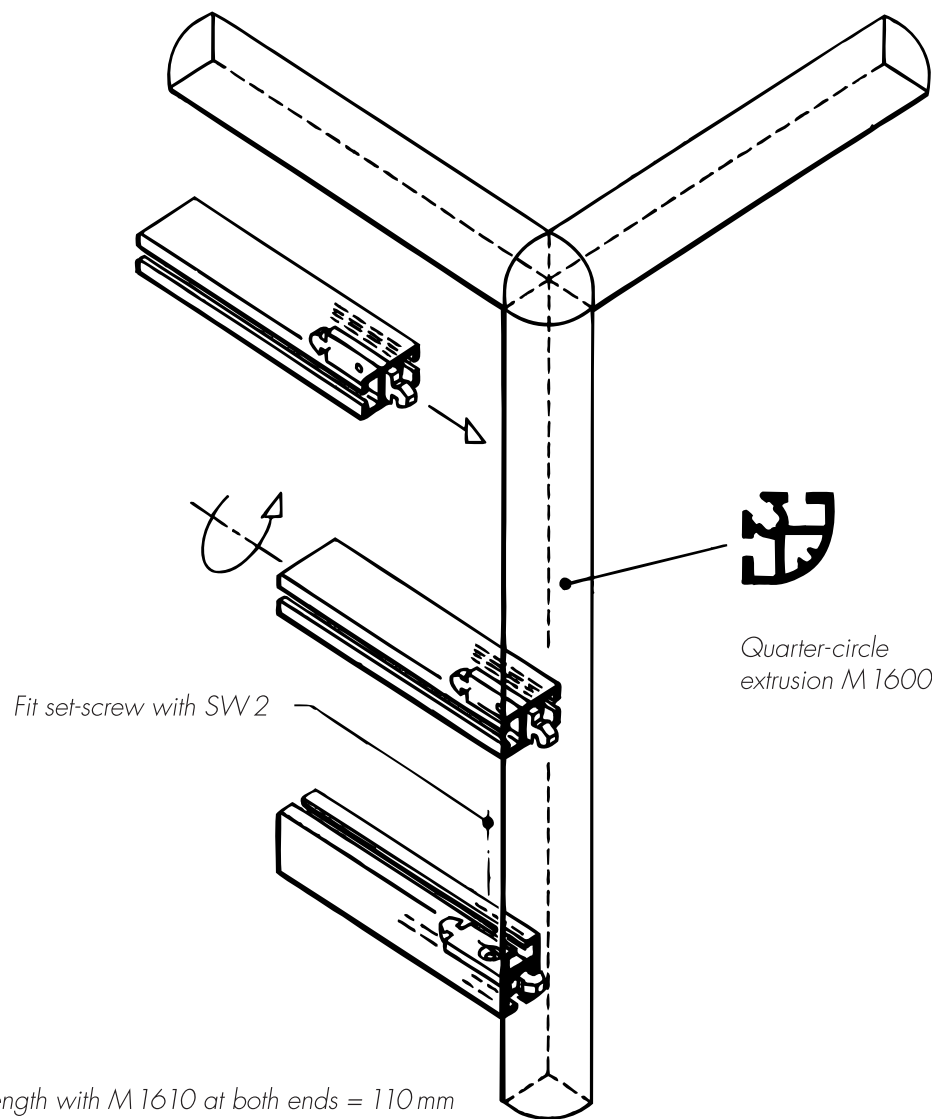

In case high loads have to be borne!

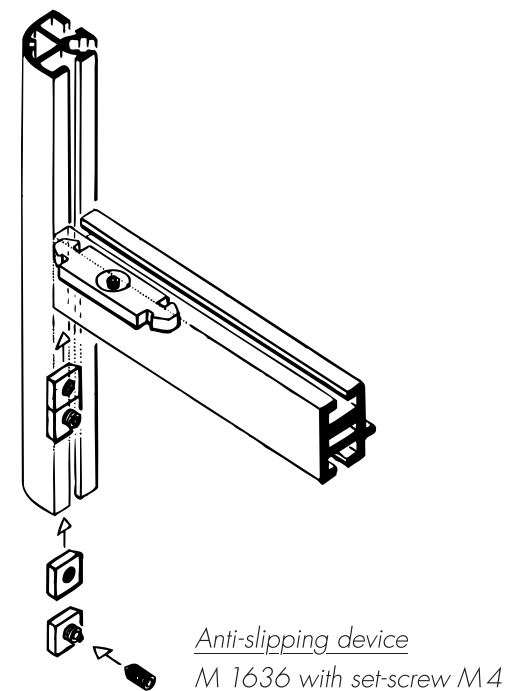

TI NL-67 10.1992.09/05 SHIFT