

ZBS 131

Special thread drill bit ZBS 131
with guiding bolt
Thread M8

Pay attention to axial thread alignment!

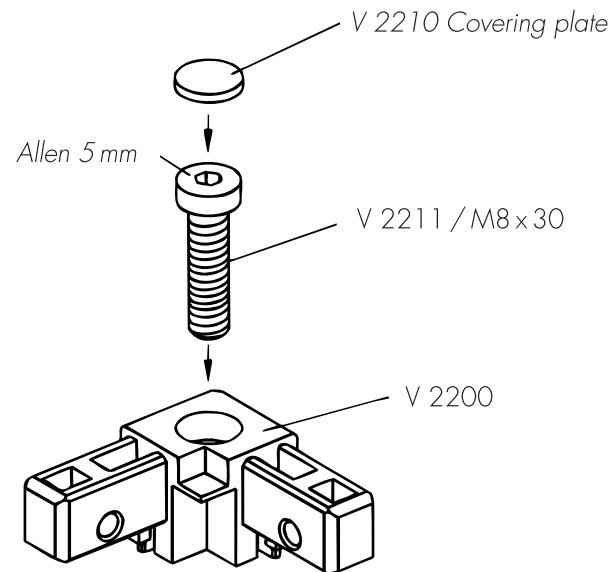

Instructions valid for the following extrusions:

