

Schraube M 1956-20 mit Mutter PL-3-22-2  
 nicht zu fest anziehen - Drehbarkeit  
 Rändelschraube M 1956-3 mit  
 2 Unterlegscheiben M 1469-40 leicht  
 festdrehen.

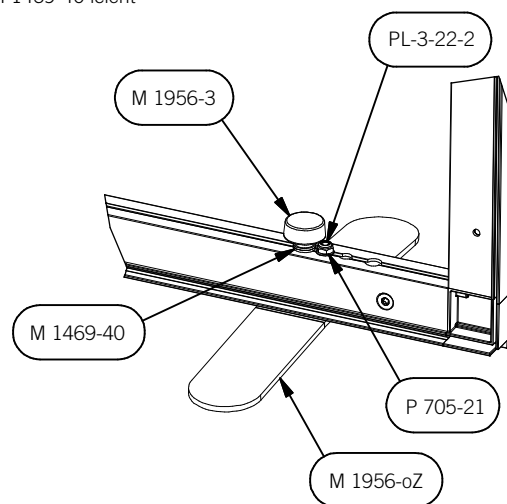

TI-OW-6.1